

Ultra-low capacitance ESD Suppressor

超低电容 ESD 抑制器

- ESD protection of high-speed data lines exceeding IEC61000-4-2:
Contact discharge typical 8 kV, max 15kV
Air discharge typical 15 kV, max 25kV
- Extremely small form factor down to 0.60x 0.30 x 0.30 mm³
- Continue working voltage: 12 Vdc max.
- Extremely low capacitance: 0.05pF typ.
- Very low clamping voltage: 35 V typ.
- Very low leakage current: <0.1 uA
- Pb-free (RoHS compliant) package
- 针对高速数据传输线路的 ESD 保护:
IEC61000-4-2,
接触放电典型值 8kV, 最大 15kV
空气放电典型值 15kV, 最大 25kV
- 极小的产品尺寸: 0.60 x 0.30 x 0.30 mm³
- 持续工作电压: 最大 12Vdc
- 超低电容: 典型值 0.05pF
- 非常低的钳位电压: 典型值 35V
- 超低漏电流: 一般小于 0.1uA
- 无铅封装

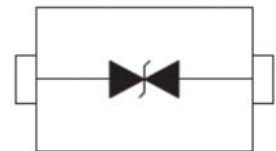
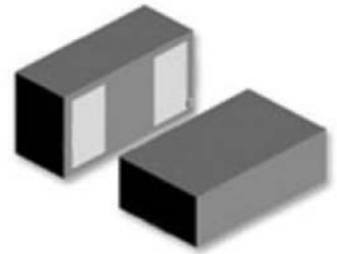

Schematic Diagram

Application

应用

- Computers and peripherals, HDTV Equipment
- DVD Players, Satellite radio, Cell phones, Digital still cameras, Digital camcorders
- Set top boxes
- High speed data ports: USB 2.0/3.0, IEEE 1394b, HDMI 1.3, DVI
- Keyboard/key switch
- 计算机及外设, HDTV 设备等
- DVD 播放器, 卫星广播, 移动电话, 数码相机, 数码 DV 等
- 机顶盒
- 高速数据接口: USB 2.0/3.0, IEEE 1394b, HDMI 1.3, DVI
- 按键开关



Electrical Characteristics

电气特性

Specification	Units	Minimum	Typical	Maximum
Operating Voltage 工作电压	V (DC)	-	-	12
Clamping Voltage 钳位电压	V	-	35	-
Trigger Voltage 触发电压	V	-	350	-
Response time 反应时间	ns	<1ns		
ESD Threat Voltage Capability ESD 保护能力	kV	IEC 61000-4-2, level 4 8 kV typical, 15kV max. Direct Discharge 15kV typical, 25kV max. Air Discharge		
Capacitance (@1MHz) 电容	pF	-	0.05	-
Leakage Current (@ 12Vdc) 漏电流	uA	-	-	0.10
Operating Temperature 工作温度	°C	-40 ~ +90		

ESD Performance

The device react within 1ns to clamp the ESD voltage.

器件在 1ns 内快速反应以钳制 ESD 电压

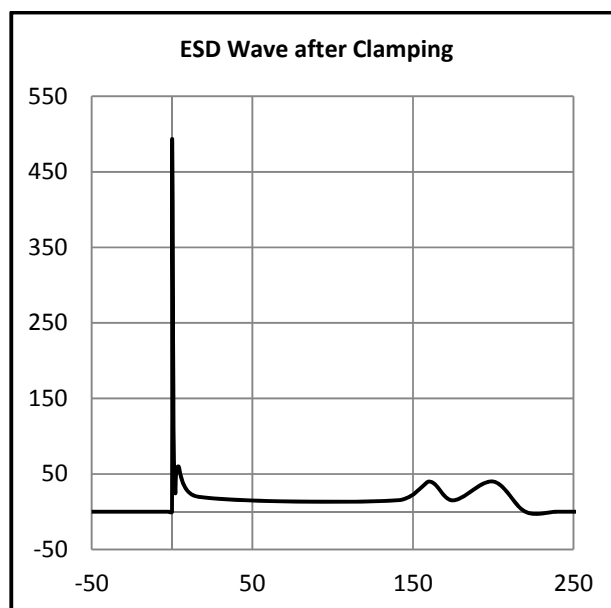

Application Examples

应用范例

Single channel, Bi-directional

单通道, 双向无极性

USB 2.0

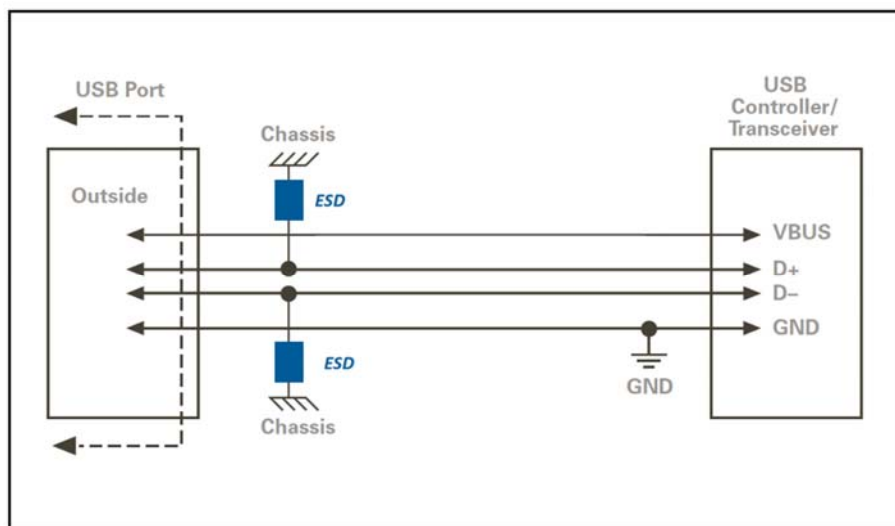

USB 3.0

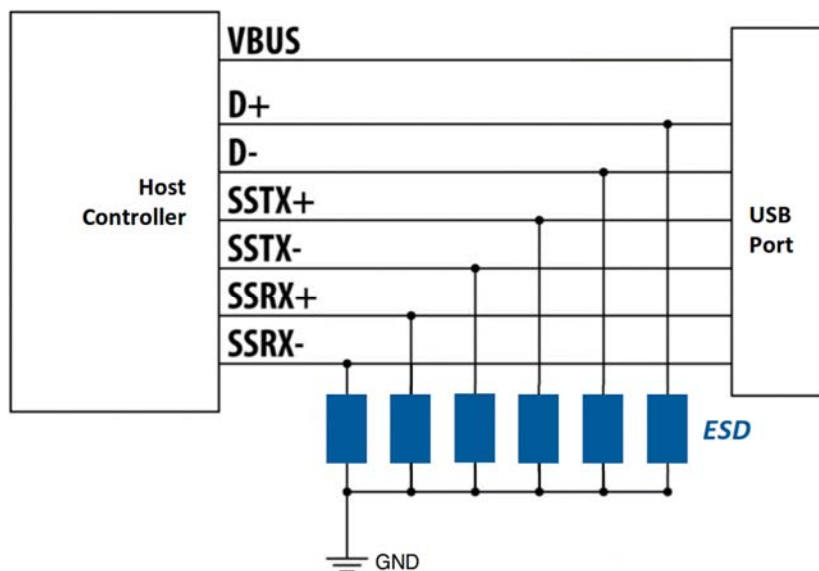

HDMI

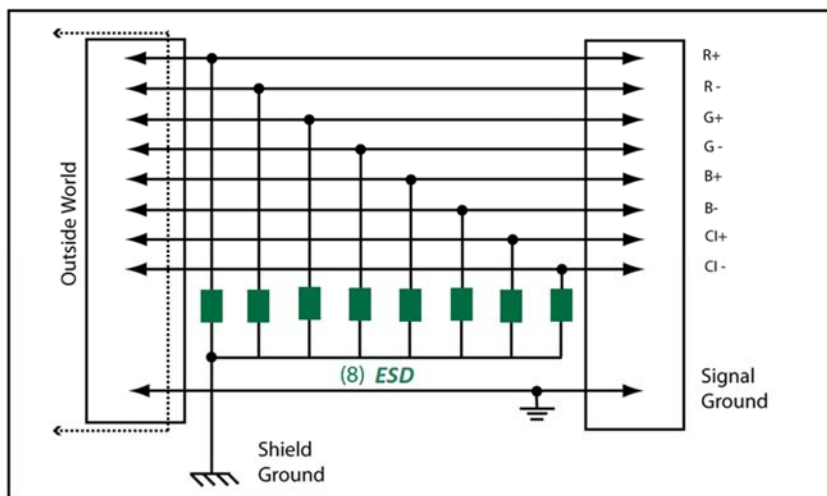

Package outline

封装尺寸

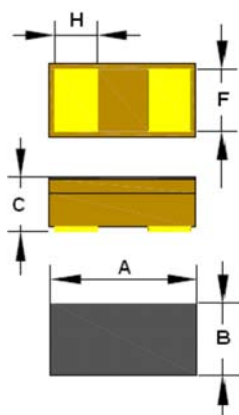

Dim.	millimeters		
	min	Typ.	max
A	0.50	0.60	0.70
B	0.25	0.30	0.35
C	0.25	0.30	0.35
H	0.18	0.20	0.22
F	0.25	0.27	0.29

Soldering pad (mm/inch)

建议焊盘尺寸

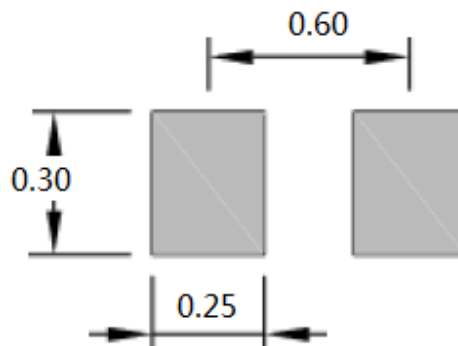

Standard Packing

标准包装

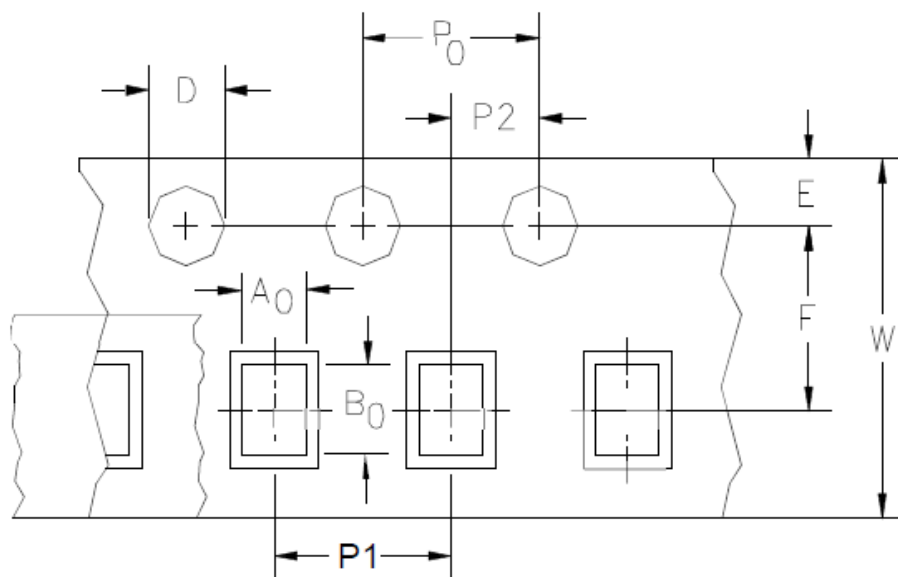

Dimension	Typical (mm)
A0	0.38
B0	0.68
D	1.55
P0	4.00
P1	2.00
P2	2.00
E	1.75
F	3.50
W	8.00

15000pcs in 7" reel per EIA Standard 481.

Edition: 2016-04-05

Published By

Advanced SurgeTech Materials Ltd.

All Rights Reserved.